

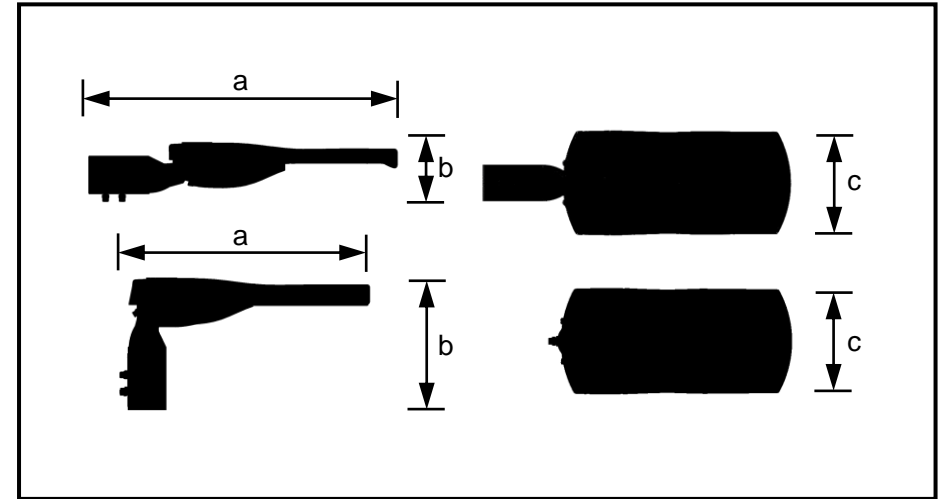



MONACO
STREETLIGHT
CLASE I/CLASS I



ART.	Peso Weight (kg)	Dimensiones Dimensions a x b, c (mm)	Superficie Surface S (m ²)
Monaco S	3,9	665 x 120 	0,044
		520 x 240 	
		218 	0,102
		218 	0,113

INSTRUCTIONS/INSTRUCCIONES

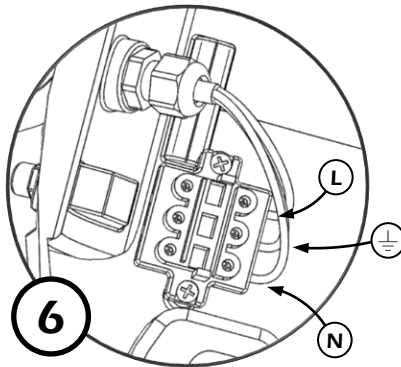
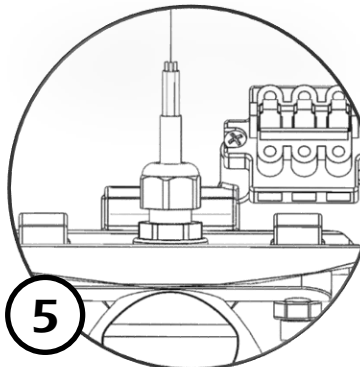
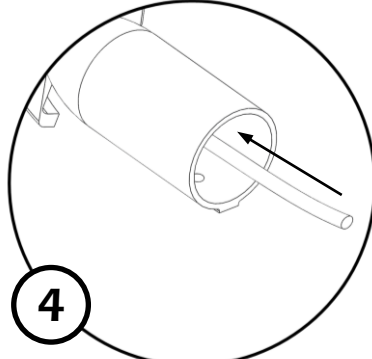
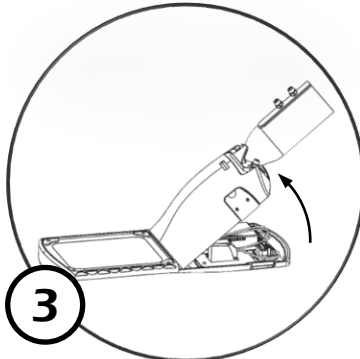
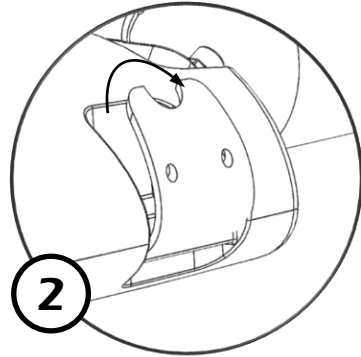
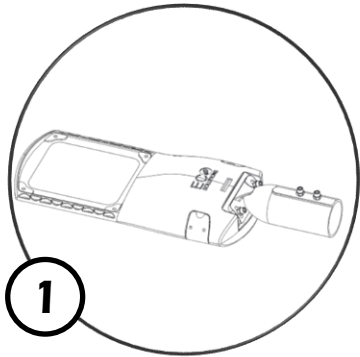

MONACO STREETLIGHT

1

ES **DETALLE DE LA FAROLA**

EN **STREETLIGHT DETAIL**

2

ES **ABRIR EL CIERRE**

SE PRESIONARÁ SOBRE LAS PESTAÑAS LATERALES DE LA FAROLA PARA LA MANIPULACIÓN DE LA MISMA.

EN **OPEN THE CLOSURE**

PRESS ON THE SIDE CLOSURE OF THE STREETLIGHT FOR HANDLING.

3

ES **ABRIR LA TAPA**

SE PROCEDE A LA APERTURA DE LA TAPA SIN FORZAR LAS BISAGRAS.

EN **OPEN THE LID**

OPEN THE LID WITHOUT FORCING THE HINGES.

4

ES **INTRODUCCIÓN DE LA MANGUERA**

SE INTRODUCE UNA MANGUERA BICAPA DE DOS HILOS POR LA PARTE INFERIOR DE LA FAROLA.

EN **OPEN THE CLOSURE**

A TWO CABLE BILAYER HOSE IS INTRODUCED BY THE BOTTOM OF THE LAMP

5

ES **PRENSAESTOPA**

SE INTRODUCE LA MANGUERA POR EL PRENSAESTOPA.

EN **STUFFING BOX**

CABLE IS INTRODUCED BY THE STUFFING BOX.

6

ES **SWITCH ON/OFF**

SE CONECTAN LOS CABLES LINEA Y NEUTRO A 'L', 'N' Y 'GND' RESPECTIVAMENTE..

EN **SWITCH ON/OFF**

CABLES NEUTRAL AND LINE IS CONNECTED TO 'N', 'L' AND 'GND' RESPECTIVELY.

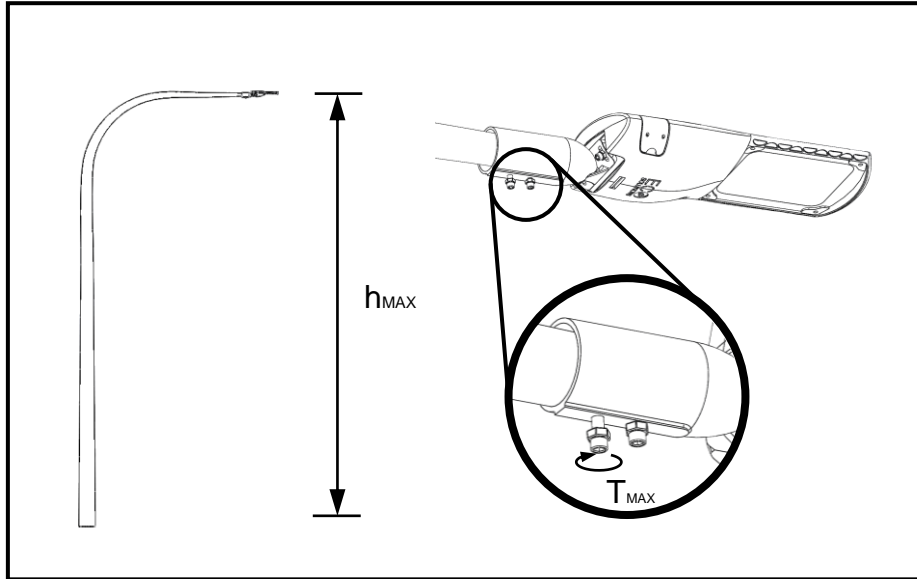

ART.	Potencia Power (W)	Altura máxima Max height h_{MAX} (m)	Max. Torque T_{MAX} (Nm)
Monaco S	40	12	16,5
	60	14	16,5

OTRAS INDICACIONES/ OTHER INDICATIONS

ES LA FUENTE DE LUZ DE ESTA LUMINARIA DEBE REEMPLAZARSE ÚNICAMENTE POR EL FABRICANTE, SU SERVICIO TÉCNICO O PERSONA CUALIFICADA EQUIVALENTE

EN THE LIGHTING SOURCE OF THIS LIGHTING MUST BE REPLACED ONLY BY THE MANUFACTURER, ITS TECHNICAL SERVICE OR EQUIVALENTLY QUALIFIED PERSON

ES ASEGURAR SE HA DESCONECTADO LA TENSIÓN ANTES DE REALIZAR LA INSTALACIÓN

EN INSURANCE THE VOLTAGE HAS BEEN DISCONNECTED BEFORE PERFORMING THE INSTALLATION

ES NO LIMPIAR LA LUMINARIA CON PRODUCTOS QUÍMICOS

EN DO NOT CLEAN THE LUMINARY WITH CHEMICALS